

Conversion

Hub Unit SK RB/RLB to Hub Unit SK RB/RLB *INTEGRAL*



SAF SERVICE und ORIGINALTEILE
SAF SERVICE and ORIGINAL PARTS

www.saf-axles.com

map & guide
location service

Edition 06/2006



Trailer Manufacturer.....

Body type.....

Chassis no.....

Year of manufacture/Trailer date in Service.....

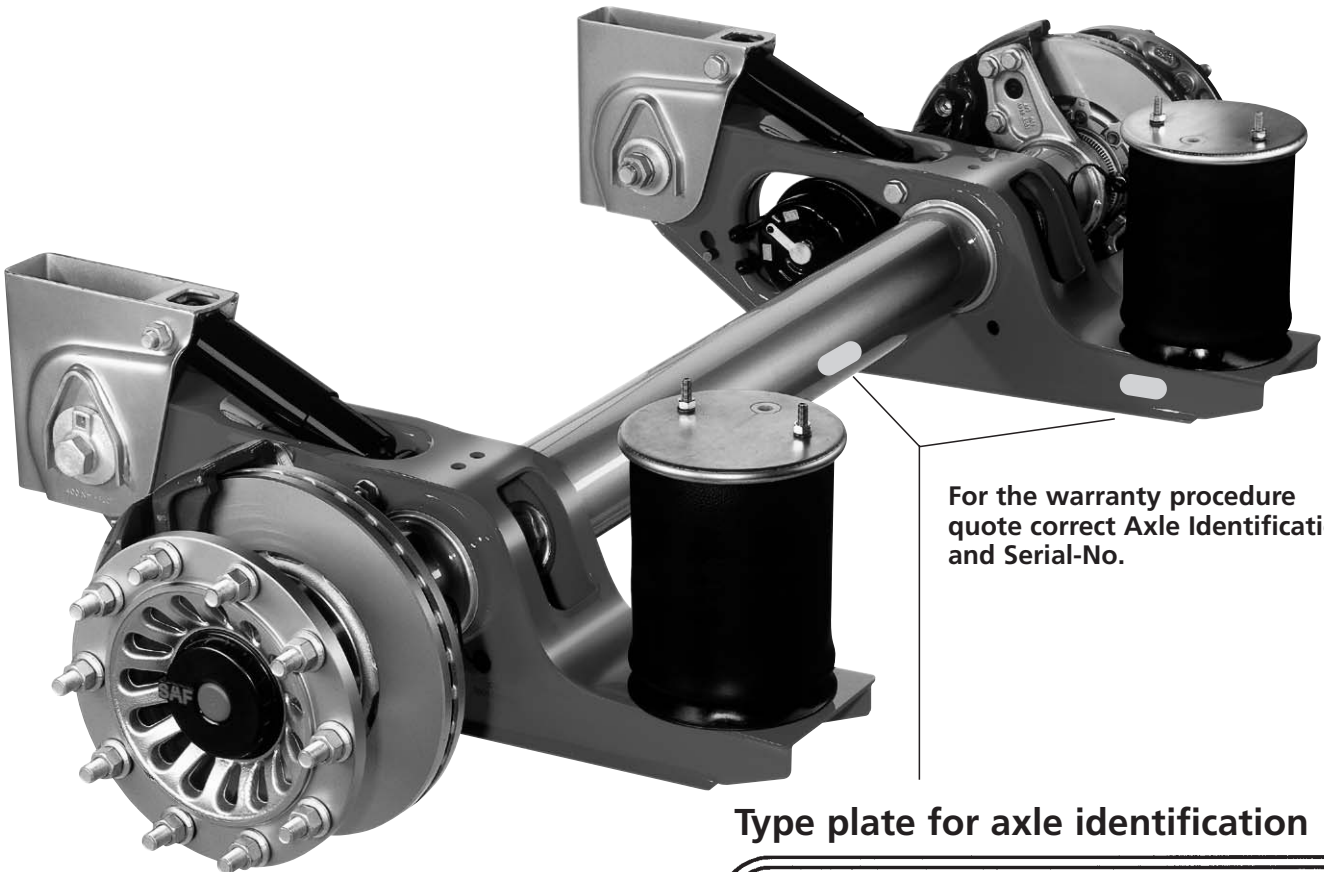

For the warranty procedure quote correct Axle Identification- and Serial-No.

Type plate for axle identification

SAF		DTTO SAUER ACHSENFABRIK KEILBERG	
		D-63854 BESSENBACH / G E R M A N Y	
TYP			
<input type="radio"/>	Ident.-No.		
	/Prod.-No.		
zul. Last	kg	STAT.	TECH.
perm. cap.			v max km/h
charge adm.			max. speed
			vitesse maxi.
TDB-No.		Grundtyp	



Identification of axles in case of type plate absence
Serial No. on spindle end, Rh side.

	Ident.-No.	Prod.-No. (Serial-No.)
Example:	14732487480	014033241
1. Axle		
2. Axle		
3. Axle		
4. Axle		
5. Axle		

Enter axle data from SAF type plate



	Page
Identification of SAF axles	2
General safety instructions	5
Service instructions	6
Hub Unit conversion kit	7
Illustration of the axle SK RB / RLB 9019 / 9022	8
Installation instructions	
Remove brake pads	9
Remove brake callipers	9
Remove Hub Unit SK RB / RLB with wheel flange and brake disc	9-10
Prepare stub axle	10
Install Hub Unit SK RB / RLB <i>INTEGRAL</i> with brake disc on stub axle	11-12
Install brake calliper on brake backing plate	12-14
Install brake pads	14
Install brake cylinder on brake calliper	14
Adjust clearance	15
Install ABS sensor	15
Tightening torques	16

Note:

Part numbers used in the text refer to the illustration of the axle SK RB / RLB 9019 / 9022

Please observe the following safety instructions in order to maintain the operational and road safety of your SAF axles and suspension systems:

1. The wheel contact surfaces between the wheel disc and wheel hub and the wheel nut contact surface at the wheel disc must not be additionally painted. The contact surfaces must be clean, smooth and free from grease. Failure to observe this may result in the wheel coming loose. Any additional instructions of the wheel manufacturer must also be observed.
2. Only the wheel and tyre sizes approved by the trailer builder may be used. The tyres must always have the specified inflation pressure.
3. The brake systems of the tractor and the trailer/semi-trailer must be synchronised by means of a tractor/trailer brake synchronisation not later than 5,000 km after the initial start of operation of the trailer/semi-trailer in order to ensure a safe and uniform braking behaviour and uniform brake pad wear. Tractor/trailer brake synchronisations should be carried out by appropriately qualified and equipped brake workshops.

The use of an additional braking system, such as a trailer anti-jackknife brake is forbidden by law on vehicles with type approval after January 1999.

4. Before starting a journey, ensure that the maximum permissible axle load is not exceeded and that the load is distributed equally and uniformly.
5. On trailers with air suspension, ensure that the air bags are completely filled with air before starting the journey. Incompletely filled air bags may result in damage to axles, suspension, frame and superstructure and impair road safety.
6. Ensure that the brakes are not overheated by continuous operation.
With drum brakes, overheating can result in a hazardous deterioration in the braking efficiency.
With disc brakes, overheating can result in damage to surrounding components – in particular the wheel bearings. This can result in a significant deterioration in road safety, e.g. failure of wheel bearings.
7. The parking brake must not be immediately applied when the brakes are hot, as the brake discs and brake drums may be damaged by different stress fields during cooling.
8. Use the supports provided when loading and unloading in order to avoid damage to the axle.
9. Observe the operating recommendation of the trailer builder for off-road operation of the installed axles and suspension systems.

The SAF definition of OFF-ROAD means driving on non-asphalted / non-concreted routes, such as e.g. gravel roads, agricultural and forestry tracks, on construction sites and in gravel pits.

Off-road operation of SAF axles and suspension systems not designed for the purpose may result in damage and hence to an impairment of road safety.

10. SAF axles and suspension systems require continuous care, service and maintenance in order to maintain operational and road safety and to be able to recognise natural wear and defects in good time.

The daily inspection of the trailer for road safety before starting the journey is one of the driver's obligations.

SAF recommends that at least the inspections and maintenance operations described on page 6 should be carried out.

We recommend the use of original SAF spare parts.

A close-knit service network of SAF partner companies is available for the technical support of the SAF axles and suspension systems and for the supply of original SAF spare parts (see rear cover or on the Internet under www.saf-axles.com).

Updates will be published as necessary on the Internet under www.saf-axles.com.

These instructions summarise using the following illustrations the steps and working sequences the steps necessary for replacing the Hub Unit with the *INTEGRAL* wheel Hub Unit on axle types SK RB / RLB 9019 / 9022 with disc brake. The tightening torques for the various items in the working steps can be found in Table 1.

Safety instructions for repair work

The perfect technical condition of the brake disc is of crucial importance for good driving and safe braking properties.

Observe the wear limits of the brake pads and brake disc! Worn brake pads and/or brake discs can lead to a deterioration in the braking efficiency or even a complete brake failure! Danger of accidents! Burnt, glazed or oily brake pads must be replaced immediately!

Brake pad replacement must always be performed for all the wheels on an axle!

During repair work on the brake system, the trailer must be standing on level ground and secured to prevent it from rolling away. Use only approved equipment for supporting and securing the trailer. During the repair work on the brake system, measures must be taken to ensure that the brakes are not actuated accidentally. The brakes must not be actuated as long as the brake pads are removed. Danger of injury!

During repair work on the brake system, do not clean soiled areas with compressed air or other high-pressure cleaners. Danger of injury!

During work on the brake system or when moving the brake calliper, hold the parts only at the outer edges to prevent fingers being trapped between brake calliper and brake bracket!

During removal and installation of the brakes on the trailer, obtain assistance from a second fitter. Heavy load! Danger of injury!

During repair work on the brakes away from the trailer, the brake must be gripped firmly in a suitable device, e.g. vice. High loosening and tightening torques of the bolts. Danger of injury!

The brake calliper with clamping unit must not be opened. For this reason, the retaining bolts of the cover on the brake calliper must not be loosened.

Carry out repair work only with recommended tools.
Do not use power wrenches or other power tools!
Tighten nuts and bolts only to the recommended tightening torques.

When new brake pads are installed, sharp braking should be avoided for the first 50 kilometres. Long braking distances and sudden braking should also be avoided.

In the event of severe damage or wear of the castings (e.g. cracks), the complete brake must be replaced.

On completing repair work, a final test should be carried out on a roller dynamometer.

Notes!

These working instructions relate only to the conversion of Hub Unit SK RB / RLB to Hub Unit SK RB / RLB *INTEGRAL*.

Illustrations in these working instructions show the conversion of Hub Unit SK RB / RLB with WABCO disc brake and apply analogously also for brake discs from other manufacturers.

For all working steps relating to the disc brake, please refer to the latest edition of the installation and maintenance instructions for the respective disc brake.

**Complete and optionally with
INTEGRAL disc 22.5" or 19.5"**



The ORIGINAL SAF *INTEGRAL* Hub Unit conversion kit includes:

Quantity	Part designation	Quantity	Part designation
2	Hub Unit groups, preassembled ready for installation, consisting of: each 1 disc 1 wheel hub assy. 10 mounting bolts 10 wheel bolts	10	Hexagon head bolts with collar
4	Pads with mounting parts	2	Shoulder bolts
20	Wheel nuts	1	Tube of stub axle grease
2	Wheel caps	1	Set of documentation with installation instructions, additional identification plate
2	O-rings		

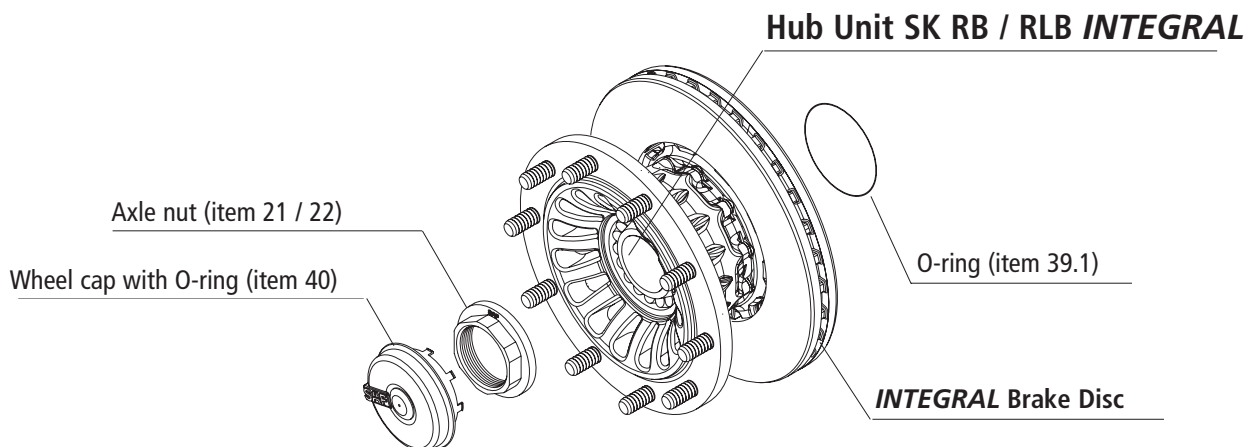
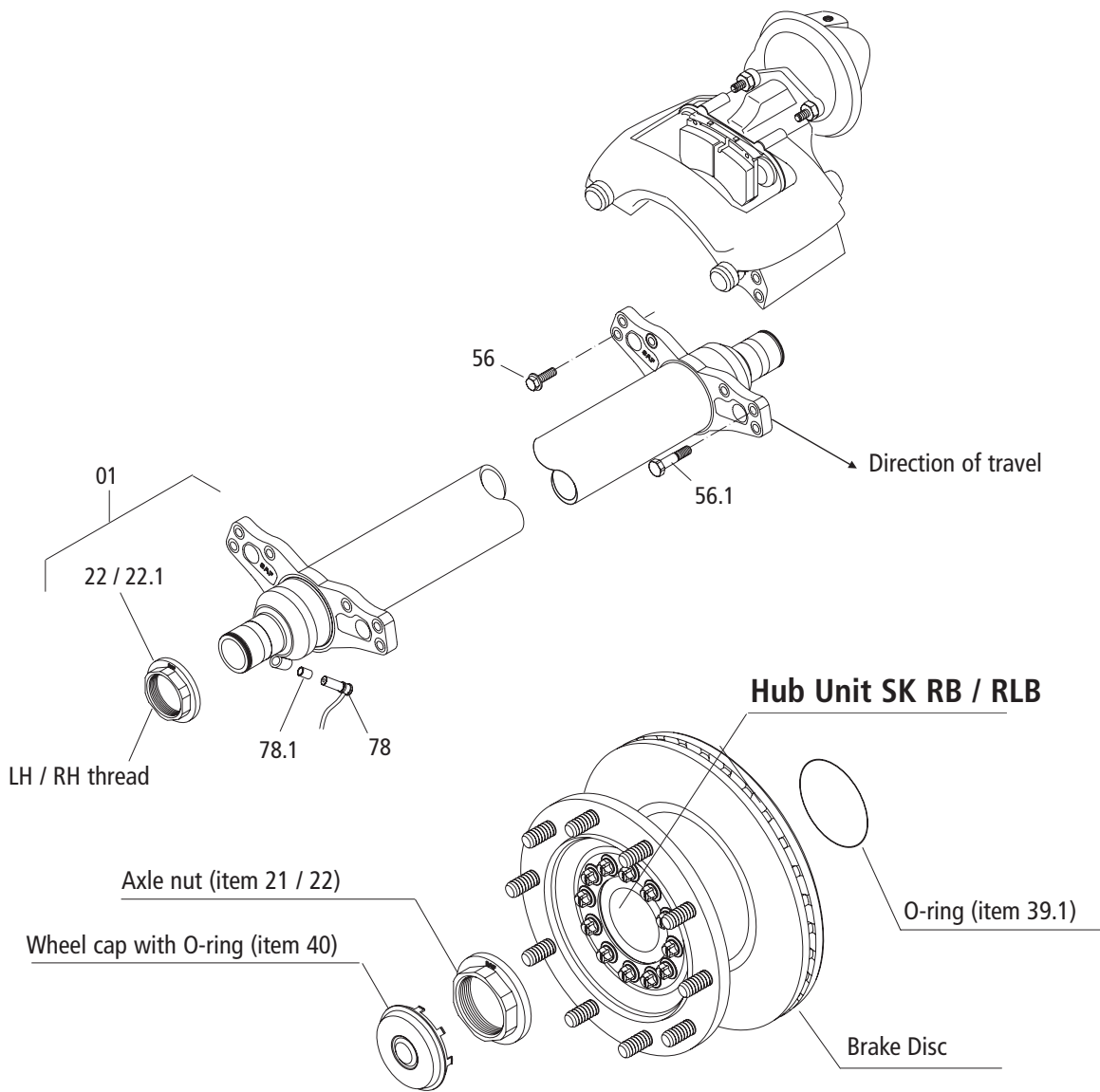



Remove brake pads

Disconnect the plug connector from the wear indicator and pull the ABS sensor out of the sensor bracket.

Loosen the mounting bolt of the pad hold-down bracket.

Pull the pad hold-down bracket out of the brake calliper

Remove the hold-down spring from the brake pads and thrust plate.

Push the brake calliper to the wheel rim side and pull out the brake pad.

Push the brake calliper inwards and remove the brake pad with thrust plate (WABCO).



Remove brake callipers

Loosen and remove the retaining nuts for the brake cylinder.

Remove the brake cylinder from the brake calliper.



Loosen and remove the mounting bolts for the brake calliper.

Remove the brake calliper from the brake backing plate.



Remove Hub Unit SK RB / RLB with wheel flange and brake disc

Remove the wheel cap from Hub Unit SK RB / RLB.



Loosen axle nut and remove from the stub axle.

Note:

On the left-hand side as seen in the direction of travel = left-hand thread.



Axle nut wrench WAF 85 (SAF Part No. 4 434 3828 00)



Remove Hub Unit SK RB / RLB complete with brake disc from the stub axle.

If necessary, pull Hub Unit SK RB / RLB from the stub axle using a puller.

Puller (SAF Part No. 4 434 3822 00)



Prepare stub axle

Clean the contact surfaces for the Hub Unit SK RB / RLB on the stub axle and coat with SAF mounting paste.

Mounting paste

(tube of grease supplied or SAF Part No. 5 387 0015 06)



Install Hub Unit SK RB / RLB *INTEGRAL* with brake disc on stub axle

Hub Unit SK RB / RLB *INTEGRAL* (see illustration).



Place a new O-ring (item 39.1) into the O-ring groove in Hub Unit SK RB / RLB *INTEGRAL*.



Push Hub Unit SK RB / RLB *INTEGRAL* onto the stub axle.



Screw on the axle nut.

Note:

On the left-hand side as seen in the direction of travel = left-hand thread



Tighten the axle nut to the prescribed tightening torque, thereby turning the Hub Unit through two revolutions.

Tightening torque, see Table 1

Note:

On the left-hand side as seen in the direction of travel = left-hand thread



Axle nut wrench WAF 85 (SAF Part No. 4 434 3828 00)

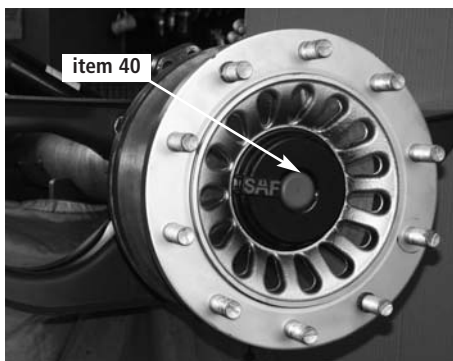

Install new wheel cap with O-ring in Hub Unit SK RB / RLB *INTEGRAL*.

Wheel cap with O-ring (item 40).

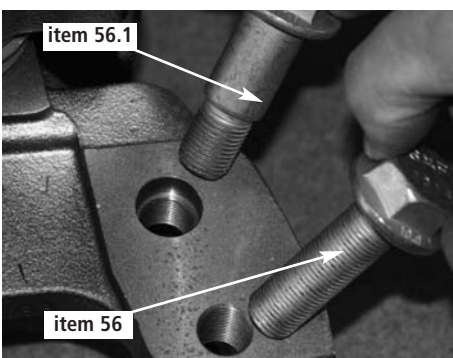

Install brake calliper on brake backing plate

Position the brake calliper on the brake backing plate and screw in the mounting bolts for the brake calliper in the correct position.

Caution!

The shoulder bolt (item 56.1) may only be screwed into the threaded bore with the recess in the brake calliper.

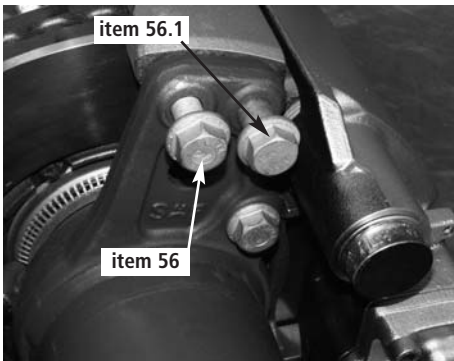

Tighten mounting bolts (items 56 and 56.1) to the prescribed tightening torque.

Caution!

Use only new hexagon head bolts / shoulder bolts (items 56 and 56.1)!

The bolts must not be oiled or greased.

Tightening torque, see Table 1



Pry out the plug for the brake adjuster using a suitable screwdriver and back off the brake at the adjusting screw.

Note:

Insert the screwdriver between plug and seal ring.

Do not place the screwdriver against the housing seal ring and pry out with force.

The seal ring must not be deformed or damaged.



When backing off the WABCO brake calliper, the thrust plate must be positioned with the pin to act as a twist lock for the thruster.

The thruster must not turn as otherwise the bellows protective cap will be damaged

Back off the brake at the hexagon of the adjuster and then turn back 1/4 turn from the end position.



Inspect the brake calliper for serviceable function and serviceability of the parts by:

- Checking the axial shiftability and sliding function
- Checking the admissible wear clearance of the guide bolts
- Checking the automatic adjustment function
- Inspecting the bellows protective caps and seals; replace the parts or the brake calliper, if necessary
- If necessary, replace defective parts or the brake calliper



Clean the slots for the brake pads and blow out.



Install brake pads

Push the brake calliper to one side and install the thrust plate (WABCO) and new brake pads.

Install the hold-down springs over the brake pads and the thrust plate.

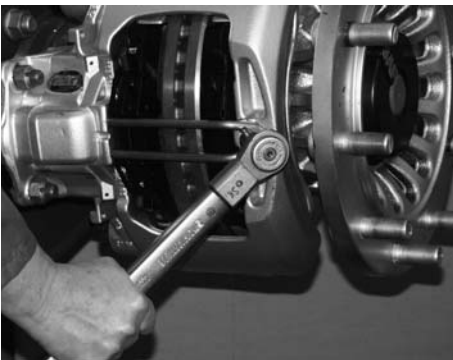

Push the pad hold-down bracket into the brake calliper.

Screw in the mounting bolt of the pad hold-down bracket and tighten to the prescribed tightening torque.

Tightening torque, see Table 1



Install brake cylinder on brake calliper

Inspect the condition of the seal on the brake cylinder flange and replace the seal, if necessary.

Inspect the sealing surface on the brake calliper and clean, if necessary.

Bolt the brake cylinder to the brake calliper and tighten the retaining nuts crosswise to the prescribed tightening torque.

Tightening torque, see Table 1



Adjust clearance by:

- Filling the compressed air system to cut-off pressure and releasing the parking brake.
- Adjusting the clearance with the adjuster.

Install the plug or cap for the adjuster again securely.

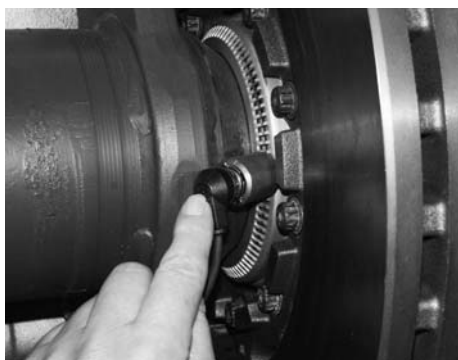

Install ABS sensor

Install the ABS sensor in the sensor bracket and push up to the exciter ring.

Attention, Attention!!

Please ensure that the additional label **ORIGINAL INTEGRAL** is put next to the type plate.

Be sure to quote for all later repair work!!!

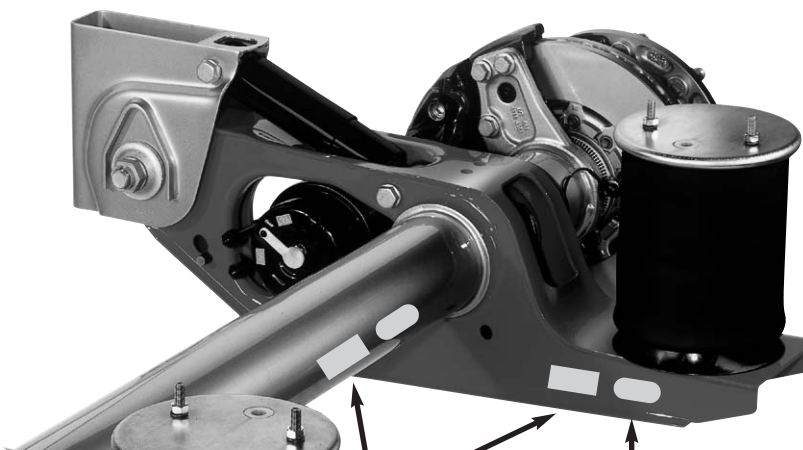

ORIGINAL
INTEGRAL

Achtung Umbau! Zur Ersatzteil-Identifikation unbedingt auf dieses Schild hinweisen.
Important – Conversion! Refer to this nameplate for spare part identification.

Attention modification! Il faut impérativement faire référence à cette plaque pour l'identification de la pièce de rechange.

Attenzione: Modifica! Per l'identificazione del pezzo di ricambio fare riferimento a questa targhetta.

¡Atención, remodelación! Para identificar las piezas de recambio, avisar de esta placa.

Внимание! Переоборудование! Для идентификации запасной части обязательно указывайте на эту табличку с указанием типа.



Axle identification plate

Caution!

After completing the conversion work, check the function of the brakes on a roller dynamometer.

Table 1

Caution!

The bolts, item 45, 56 and 56.1 must be replaced during all repair work.

The bolts must not be oiled or greased.

Tighten all bolts using a torque wrench.

Bolted connections	Item No.	Tightening torques (Nm)
Axle nuts	21 / 22	Pretightening: 150 Nm, whilst turning the hub unit evenly by 5 revolutions. Final tightening: tighten further by 30°
<i>INTEGRAL</i> -Brake Disc Double hex. bolt, socket 13, M12 x 1.5	45	1. pre-tighten diagonally with 30 Nm 2. further tighten diagonally with torque angle 90° (in-service inspection torque 150 Nm)
Brake calliper on axle Hexagon bolt M16 x 1.5	56 56.1	290 Nm
Brake chamber hex. nut M16 x 1.5		Tighten alternately and uniformly in 2 stages 1. Pretightening 120 Nm 2. Torque angle 210 Nm (in-service inspection torque 210 Nm)

Soforthilfe im Pannenfall

NonStopService 24

Support in the case of service

- Im Servicefall wählen Sie bitte **immer** die Rufnummer Ihres **Heimatlandes**.
- In the case of service please **always** dial the number of your **own country**.

Inland home country		Vom Ausland from abroad
03 62 27 23 21	(A)	+43 3 62 27 23 21
0 59 33 07 07	(B)	+32 59 33 07 07
+30 21 09 40 19 80	(BG)	+30 21 09 40 19 80
+386 26 16 58 35	(BIH)	+386 26 16 58 35
0 19 08 64 90	(CH)	+41 19 08 64 90
2 61 10 45 06	(CZ)	+42 02 61 10 45 06
0800 72 37 37 84 / 0 73 33 80 81 58	(D)	00800 72 37 37 84 / +49 73 33 80 81 58
75 72 74 74	(DK)	+45 75 72 74 74
9 02 18 19 92	(E)	+34 9 13 82 68 41
697 91 96	(EST)	+372 697 91 96
03 88 72 06 43	(F)	+3 33 88 72 06 43
0 93 51 31 33	(FIN)	+35 8 93 51 31 33
+41 19 08 64 90	(FL)	+41 19 08 64 90
0 87 02 42 02 37	(GB)	+44 87 02 42 02 37
21 09 40 19 80	(GR)	+30 21 09 40 19 80
06 13 45 17 27	(H)	+36 13 45 17 27
+386 26 16 58 35	(HR)	+386 26 16 58 35
02 66 16 55 74	(I)	+39 02 66 16 55 74
+44 87 02 42 02 37	(IRL)	+44 87 02 42 02 37
+32 59 33 07 07	(L)	+32 59 33 07 07
+372 697 91 96	(LT)	+372 697 91 96
+372 697 91 96	(LV)	+372 697 91 96
+33 3 88 72 06 43	(MC)	+33 3 88 72 06 43
+386 26 16 58 35	(MK)	+386 26 16 58 35
+45 75 72 74 74	(N)	+45 75 72 74 74
+32 59 33 07 07	(NL)	+32 59 33 07 07
+34 9 13 82 68 41	(P)	+34 9 13 82 68 41
06 18 31 98 70	(PL)	+48 6 18 31 98 70
02 12 50 02 60	(RO)	+40 2 12 50 02 60
+39 02 66 16 55 74	(RSM)	+39 02 66 16 55 74
+45 75 72 74 74	(S)	+45 75 72 74 74
+42 02 61 10 45 06	(SK)	+42 02 61 10 45 06
0 26 16 58 35	(SLO)	+386 26 16 58 35
0 21 22 75 13 21	(TR)	+90 21 22 75 13 21
+386 26 16 58 35	(YU)	+386 26 16 58 35

www.saf-axles.com

Otto Sauer Achsenfabrik GmbH · Hauptstraße 26 · D-63856 Bessenbach
Tel +49 (0) 60 95 / 301-0 · Fax +49 (0) 60 95 / 301-259 · www.saf-axles.com

